

Drive Couplings

Technical Data



Materials

Coupling halves
Sintered Steel

Sleeve
Nylon 66

Max temp sleeve
83°C

To select coupling model check application to establish running load condition.

Check chart for factor (F) and apply factor (F) to *Rating of coupling formulae. This answer you now apply to *Rating/100 rev/min below.

It is advisable always to check shaft sizes being used on application and check with dimension 'H'.

Application	Factor (F)	
	Electric motor	Petrol/diesel engine
Uniform load	1.00	1.20
Medium shock	1.25	1.50
Heavy shock	1.75	2.00

$$\text{*Rating of coupling} = \frac{\text{HP of application} \times 100 \times F}{\text{rev/min of application}}$$

Installation Details

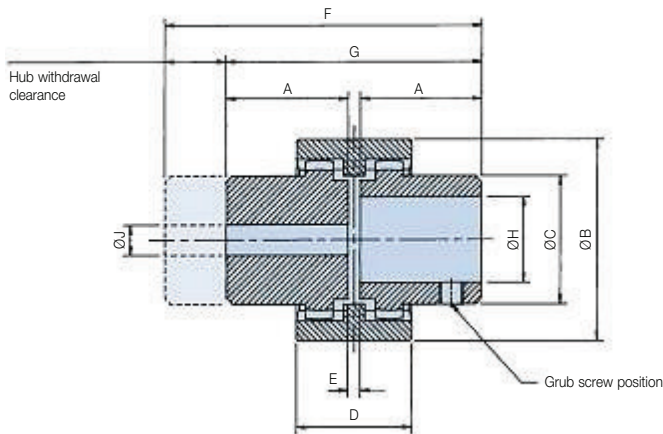

Sectioned detail

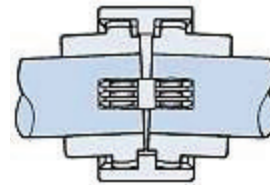

Part number prefix	Max speed rev/min	*Rating/ 100 rev/min		Weight	A mm	B mm	C mm	D mm	E mm	F mm	G mm	max bore	-H- min bore	J pilot bore
DC28*	5000	0.75	1.00	0.4	40.0	66.0	44.5	38.0	4.0	104.0	84.0	28.0	10.0	7.0
DC42*	5000	1.32	1.75	0.75	42.0	90.0	60.0	42.0	4.0	115.0	88.0	42.0	14.0	10.5
DC55*	4000	6.00	8.00	2.05	59.0	125.0	83.0	65.0	4.0	158.0	122.0	55.0	19.0	16.0 min 38.1 max

Height of keyway from base of bore

	Metric	Imperial
Standard bore	BS 4500, (1985)	BS 1916, Part 1, (1985)
Standard keyway	BS 4325, Part 1 (1980)	BS 46, Part 1, (1985)

Assembly data

1. Maximum angular misalignment is ±2°. Maximum radial misalignment is ±0.4mm.
2. Ensure that the Parker Filtration drive coupling gear hubs are an easy fit to their respective shafts. Do not use heavy blows to force the hubs on.
3. When in position, the hubs should have a gap of 4mm as denoted by 'E' dimension.
4. Tighten grub screws to locate both gear hubs on to their respective shafts.

Ordering Examples

Parker Filtration drive coupling components are ordered separately. Here are three examples of complete assemblies ordered this way.

1. Complete assembly – **DC28M14B04K**
Made up of a **DC28M14**
DC28B04K
DC28.S (Sleeve)

Complete model **DC28** drive coupling: One gear hub has 14mm bore with 5mm wide keyway and other hub has a 1/2" bore with 0.125" wide keyway.

Both hubs supplied with locating grub screw.

2. Complete assembly – **DCR42PBPB**
Made up of 2x **DCR42PB's**
DC42S (Sleeve)

Complete model **DC42** drive coupling: Both gear hubs have pilot bore of 10.5mm. Not supplied with grub screws.

3. Complete assembly – **DCR55PBB12K**
Made up of a **DCR55PB**
DC55B12K
DC55S (Sleeve)

Complete model **DC55** drive coupling: One gear hub pilot bored 5/8", the other hub pilot bored 1 1/2". Latter only supplied with grub screw.

Drive Couplings

Ordering Information

Model DC.28

Part number	Supersedes	Dimensions (mm)			Weight
		Ø Bore	Width	Height	
DC28M16	DC.28.M16	16.0mm	5.0mm	18.4mm	Range from 0.259Kg to 0.411Kg
DC28M19	DC.28.M19	19.0mm	6.0mm	21.9mm	
DC28M20	DC.28.M20	20.0mm	6.0mm	22.9mm	
DC28M22	DC.28.M22	22.0mm	6.0mm	24.9mm	
DC28M24	DC.28.M24	24.0mm	8.0mm	27.5mm	
DC28M25	DC.28.M25	25.0mm	8.0mm	28.5mm	
DC28M28	DC.28.M28	28.0mm	8.0mm	31.5mm	
DCR28PB	DCR.28.PB	N/A	8.0mm	N/A	
DC28S	DC.28.S	N/A	N/A	N/A	
DC28M10	DC.28.M10	10.0mm	3.0mm	11.5mm	
DC28M11	DC.28.M11	11.0mm	4.0mm	12.9mm	
DC28M14	DC.28.M14	14.0mm	5.0mm	16.4mm	
DC28M18	DC.28.M18	18.0mm	6.0mm	20.9mm	
DC28B03K	DC.28.B03K	7/16	0.125 ins	0.50 ins	
DC28B04K	DC.28.B04K	1/2	0.125 ins	0.57 ins	
DC28B05K	DC.28.B05K	5/8	0.188 ins	0.72 ins	
DC28B06K	DC.28.B06K	3/4	0.188 ins	0.84 ins	
DC28B07K	DC.28.B07K	7/8	0.250 ins	0.99 ins	
DC28B08K	DC.28.B08K	1	0.250 ins	1.12 ins	
DC28B09K	DC.28.B09K	1 1/8	0.313 ins	1.24 ins	

Model DC.42

Part number	Supersedes	Dimensions (mm)			Weight
		Ø Bore	Width	Height	
DC42M25	DC.42.M25	25.0mm	8.0mm	28.5mm	Range from 0.436Kg to 0.753Kg
DC42M28	DC.42.M28	28.0mm	8.0mm	31.5mm	
DC42M30	DC.42.M30	30.0mm	8.0mm	33.5mm	
DC42M35	DC.42.M35	35.0mm	10.0mm	38.5mm	
DC42M38	DC.42.M38	38.0mm	10.0mm	41.5mm	
DC42M42	DC.42.M42	42.0mm	12.0mm	45.5mm	
DCR42PB	DCR.42.PB	N/A	12.0mm	N/A	
DC42S	DC.42.S	N/A	N/A	N/A	
DC42M18	DC.42.M18	18.0mm	6.0mm	20.9mm	
DC42M19	DC.42.M19	19.0mm	6.0mm	21.9mm	
DC42M20	DC.42.M20	20.0mm	6.0mm	22.9mm	
DC42M22	DC.42.M22	22.0mm	6.0mm	24.9mm	
DC42M24	DC.42.M24	24.0mm	8.0mm	27.5mm	
DC42M32	DC.42.M32	32.0mm	10.0mm	35.5mm	
DC42B05K	DC.42.B05K	5/8	0.188 ins	0.72 ins	
DC42B06K	DC.42.B06K	3/4	0.188 ins	0.84 ins	
DC42B07K	DC.42.B07K	7/8	0.250 ins	0.99 ins	
DC42B08K	DC.42.B08K	1	0.250 ins	1.12 ins	
DC42B09K	DC.42.B09K	1 1/8	0.313 ins	1.24 ins	
DC42B10K	DC.42.B10K	1 1/4	0.313 ins	1.37 ins	
DC42B11K	DC.42.B11K	1 3/8	0.375 ins	1.49 ins	
DC42B12K	DC.42.B12K	1 1/2	0.375 ins	1.61 ins	
DC42B13K	DC.42.B13K	1 5/8	0.439 ins	1.76 ins	

Model DC.55

Part number	Supersedes	Dimensions (mm)			Weight
		Ø Bore	Width	Height	
DCR55PB	DCR.55.PB	N/A	16.0mm	N/A	Range from 1.248 Kg – 2.046 Kg
DC55S	DC.55.S	N/A	N/A	N/A	
DC55M25	DC.55.M25	25.0mm	8.0mm	28.5mm	
DC55M28	DC.55.M28	28.0mm	8.0mm	33.5mm	
DC55M30	DC.55.M30	30.0mm	8.0mm	33.5mm	
DC55M32	DC.55.M32	32.0mm	10.0mm	35.5mm	
DC55M35	DC.55.M35	35.0mm	10.0mm	38.5mm	
DC55M38	DC.55.M38	38.0mm	10.0mm	41.5mm	
DC55M42	DC.55.M42	42.0mm	12.0mm	45.5mm	
DC55M55	DC.55.M55	55.0mm	16.0mm	59.5mm	
DC55B09K	DC.55.B09K	1 1/8	0.313 ins	1.24 ins	
DC55B10K	DC.55.B10K	1 1/4	0.313 ins	1.37 ins	
DC55B11K	DC.55.B11K	1 3/8	0.375 ins	1.49 ins	
DC55B12K	DC.55.B12K	1 1/2	0.375 ins	1.61 ins	
DC55B13K	DC.55.B13K	1 5/8	0.439 ins	1.76 ins	
DC55B14K	DC.55.B14K	1 3/4	0.439 ins	1.89 ins	
DC55B15K	DC.55.B15K	1 7/8	0.501 ins	2.01 ins	
DC55B16K	DC.55.B16K	2	0.501 ins	2.13 ins	
DC55B17K	DC.55.B17K	2 1/8	0.626 ins	2.31 ins	

Note 1: Part numbers featured with bold highlighted codes will ensure a 'standard' product selection.
 Note 2: Alternate displayed part number selection will require you to contact Parker Filtration for availability.